

Surname	Centre Number	Candidate Number
First name(s)		0

**GCSE**

3300U30-1



A24-3300U30-1

**MONDAY, 11 NOVEMBER 2024 – MORNING**

**MATHEMATICS**  
**UNIT 1: NON-CALCULATOR**  
**INTERMEDIATE TIER**

1 hour 45 minutes

**ADDITIONAL MATERIALS**

The use of a calculator is not permitted in this examination.  
 A ruler, protractor and a pair of compasses may be required.

**INSTRUCTIONS TO CANDIDATES**

Use black ink or black ball-point pen. Do not use gel pen or correction fluid.

You may use a pencil for graphs and diagrams only.

Write your name, centre number and candidate number in the spaces at the top of this page.

Answer **all** questions.

Write your answers in the spaces provided in this booklet. If you run out of space, use the additional page(s) at the back of the booklet, taking care to number the question(s) correctly.

Take  $\pi$  as 3.14.

**INFORMATION FOR CANDIDATES**

You should give details of your method of solution when appropriate.

Unless stated, diagrams are not drawn to scale.

Scale drawing solutions will not be acceptable where you are asked to calculate.

The number of marks is given in brackets at the end of each question or part-question.

In question 5, the assessment will take into account the quality of your linguistic and mathematical organisation, communication and accuracy in writing.

For Examiner's use only		
Question	Maximum Mark	Mark Awarded
1.	5	
2.	2	
3.	6	
4.	5	
5.	6	
6.	4	
7.	6	
8.	4	
9.	3	
10.	3	
11.	4	
12.	5	
13.	6	
14.	2	
15.	5	
16.	7	
17.	3	
18.	4	
<b>Total</b>	<b>80</b>	



NOV243300U30101

**Formula List – Intermediate Tier**

**Area of trapezium** =  $\frac{1}{2}(a + b)h$

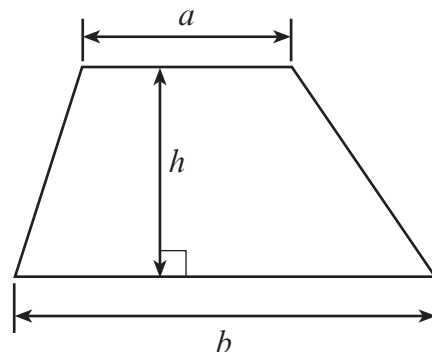

**Volume of prism** = area of cross-section  $\times$  length

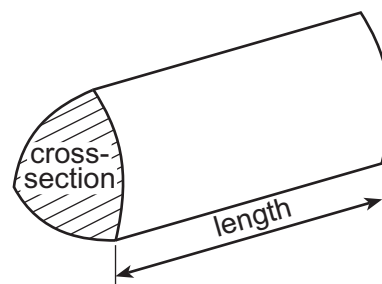

1. A number machine is shown below.

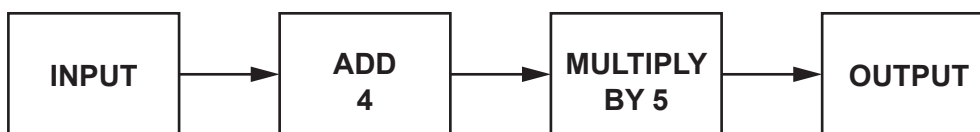

Complete the table below.

[5]

INPUT	OUTPUT
-7	
	-100
2.5	
$n$	

Space for working:

.....

.....

.....

.....

.....

.....

.....

.....

.....

.....

2. **Estimate** the value of  $33 \times 7940$ .  
You must show your approximations in your working.

[2]

.....

.....

.....

.....



3. (a) Simplify the expression  $7g - 8f - 4g + 3f$ . [2]

.....

.....

(b) Use the formula  $F = 5T + 4R$  to find the **value of R** when  $F = 23$  and  $T = 3$ . [3]

.....

.....

.....

.....

.....

(c) Which of the lines below is represented by the equation  $y = 2$ ? Circle your answer. [1]

Line A                      Line B                      Line C                      Line D                      Line E

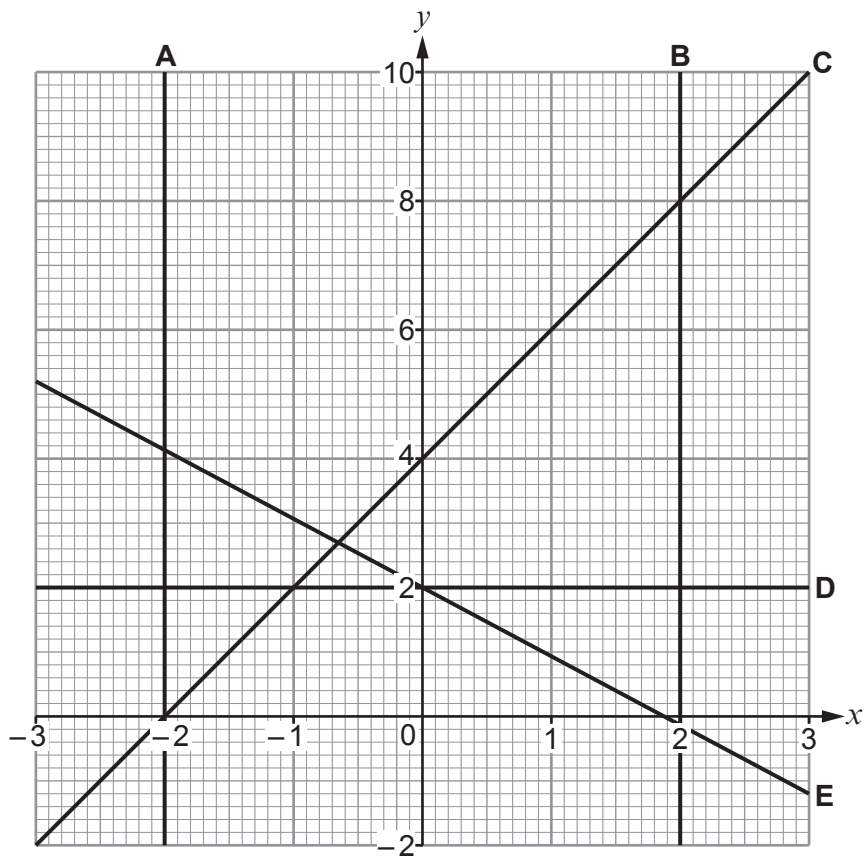

4. Bethan has two brothers, Andrew and Richard.

Andrew is 7 years older than Bethan.  
Richard is 3 years older than Andrew.

(a) Today, the sum of all their ages is 59 years.  
How old are Bethan, Andrew and Richard today? [2]

.....  
.....  
.....  
.....  
.....  
.....  
.....  
.....

Bethan = ..... years old

Andrew = ..... years old

Richard = ..... years old

(b) (i) Write down the ratio of Andrew's age to Richard's age when Andrew is 27.  
Write the ratio in its simplest form. [2]

.....  
.....  
.....

Ratio of Andrew's age to Richard's age = ..... : .....

(ii) Explain why the ratio of Andrew's age to Richard's age can never be 1 : 1. [1]

.....  
.....  
.....

3300U301  
05



5. In this question, you will be assessed on the quality of your organisation, communication and accuracy in writing.

The diagram below shows the cross-section of a solid.

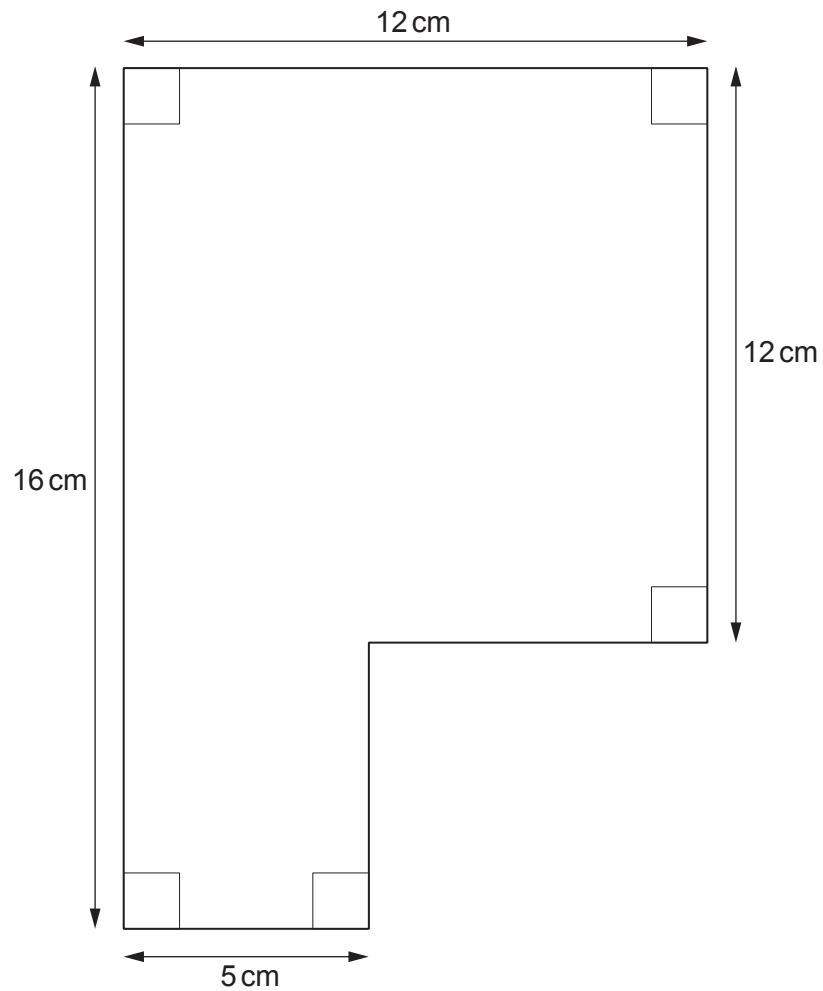

The solid has a height of 2 cm.

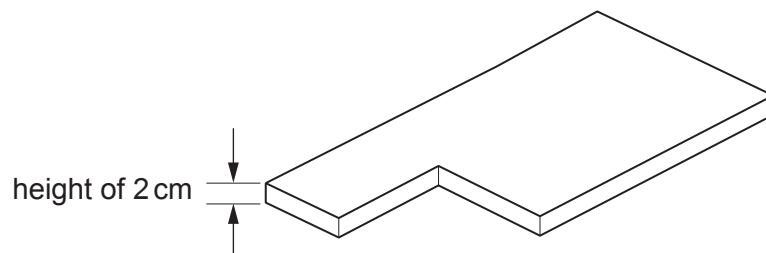

*Diagrams not drawn to scale*





6. Three of the four vertices of a parallelogram have the following coordinates.

(4, 3)      (5, -1)      (8, 3)

Plot these points on the coordinate grid below.

Then, plot **all three** possible points for the fourth vertex.  
Write down the coordinates of these three points.

[4]

.....

.....

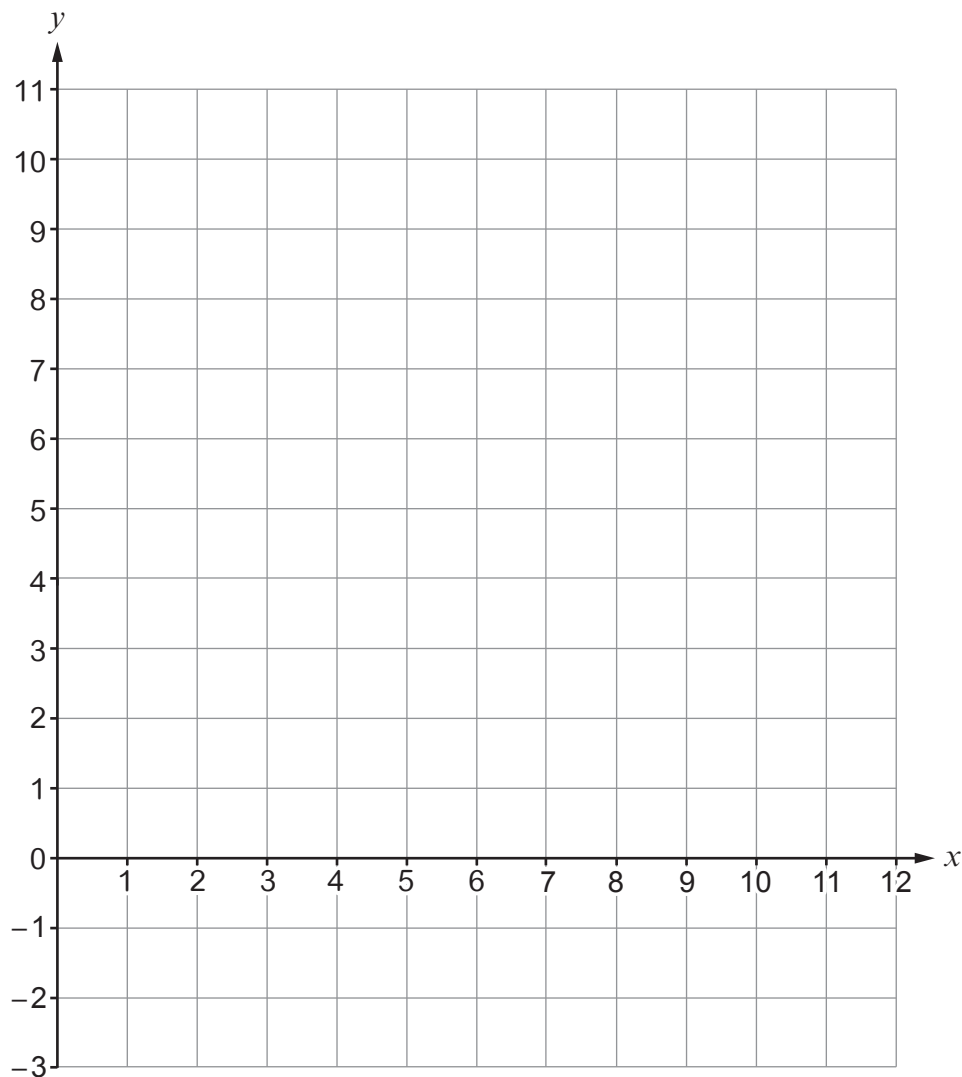

The **three** possible points for the fourth vertex are

(..... , ..... )    (..... , ..... )    (..... , ..... )







9. Calculate the area of the trapezium shown below.  
You must give the units of your answer.

[3]

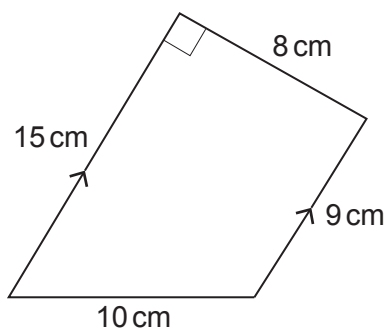
Examiner  
only

*Diagram not drawn to scale*

.....

.....

.....

.....

.....

.....

10. Express 945 as a product of its prime factors in index form.

[3]

.....

.....

.....

.....

.....

.....

.....

.....

.....

.....

.....



Examiner only

11. The table below shows some of the values of  $y = 2x^2 + x + 3$  for values of  $x$  from  $-2$  to  $3$ .

$x$	$-2$	$-1$	$0$	$1$	$2$	$3$
$y = 2x^2 + x + 3$		$4$	$3$	$6$		$24$

(a) Complete the table by finding the values of  $y$  for  $x = -2$  and for  $x = 2$ . [2]

.....

.....

.....

.....

(b) On the graph paper below, draw the graph of  $y = 2x^2 + x + 3$  for values of  $x$  from  $-2$  to  $3$ . [2]

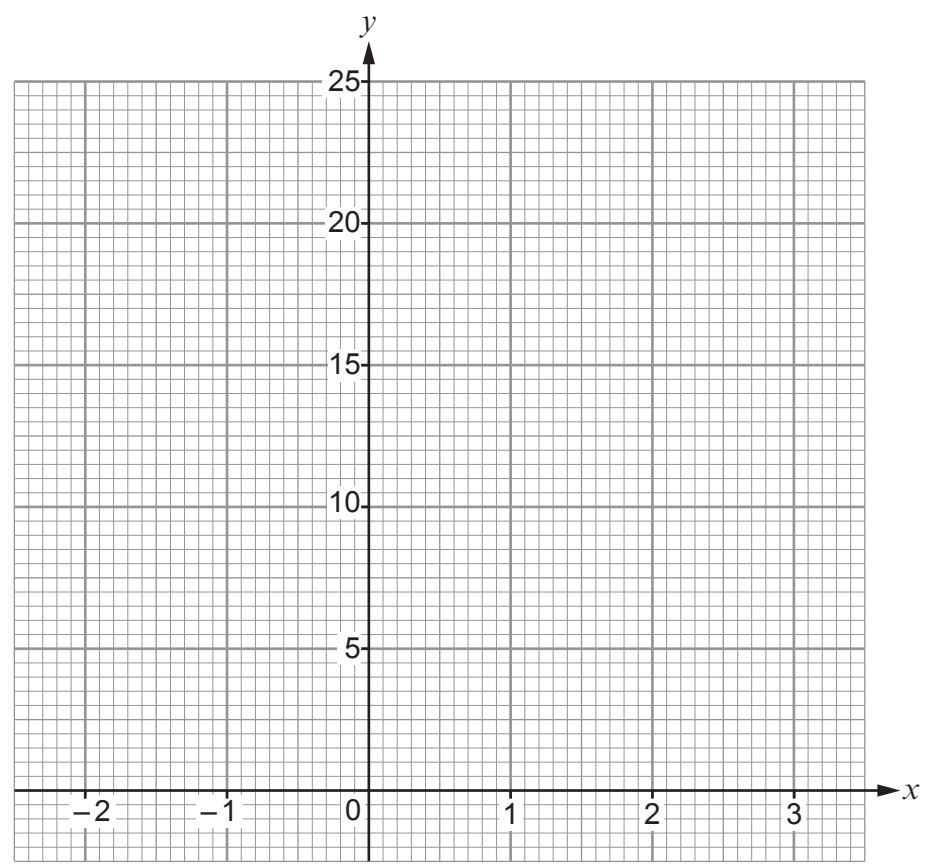



Examiner  
only

13. A cyclist travels for 2 hours at an average speed of  $x$  miles per hour.  
She then travels for a further 3 hours at an average speed of  $(x + 6)$  miles per hour.  
She travels a total distance of 78 miles.

Form an equation, in terms of  $x$ , to represent the total distance she travels.  
Solve your equation and use your solution to complete the statements below. [6]

.....

.....

.....

.....

.....

.....

.....

.....

.....

.....

.....

.....

.....

.....

.....

.....

.....

.....

.....

.....

.....

.....

.....

First, the cyclist travels for 2 hours at an average speed of ..... miles per hour.

Then, she travels for a further 3 hours at an average speed of ..... miles per hour.



14. The two shapes below are mathematically similar.

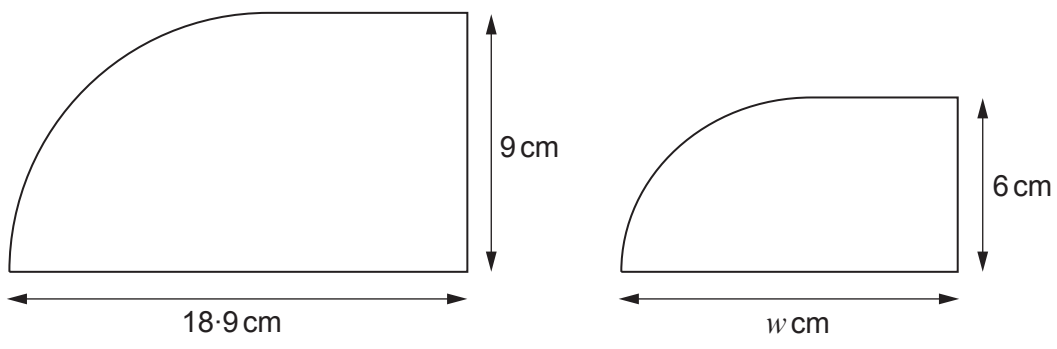

*Diagrams not drawn to scale*

Calculate the value of  $w$ .

[2]

.....

.....

.....

.....

.....

.....

.....

.....

.....

.....



Examiner only

15. Evan and Jane each shoot one arrow at a target.  
 The probability that Evan hits the centre of the target is 0.4.  
 The probability that Jane hits the centre of the target is 0.45.



(a) Complete the tree diagram below.

[3]

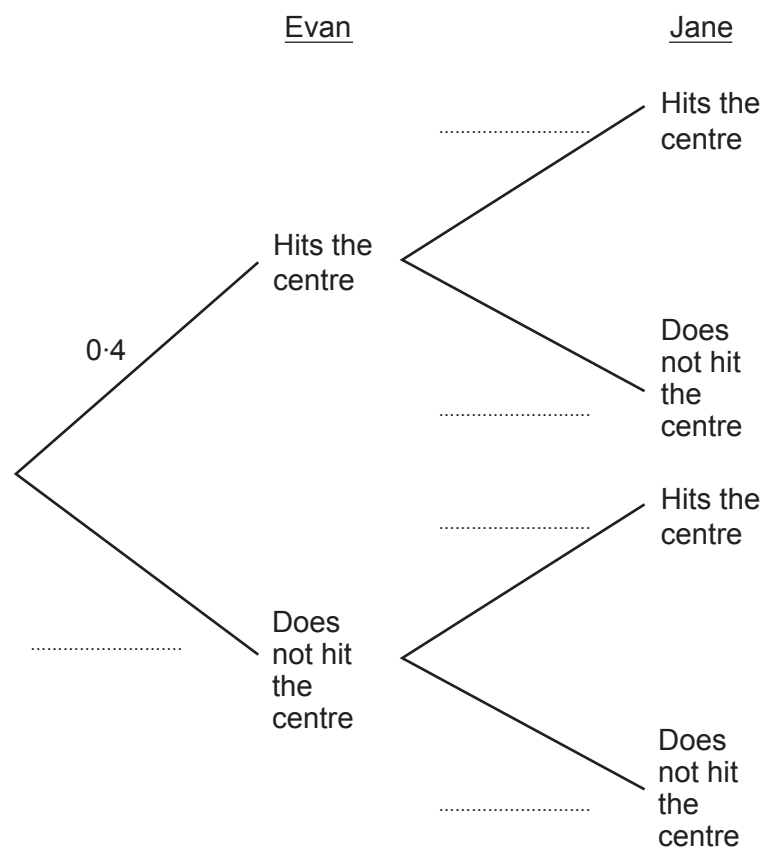

(b) Find the probability that Evan and Jane both hit the centre of the target.

[2]

.....

.....

.....

.....

.....

.....

.....



**16.** A rectangle has length  $(x + 5)$  cm and width  $(x + 3)$  cm.  
The area of the rectangle is  $120 \text{ cm}^2$ .

(a) Show that  $x^2 + 8x - 105 = 0$ .

[2]

.....

.....

.....

.....

.....

.....

(b) Factorise  $x^2 + 8x - 105$ , and hence solve  $x^2 + 8x - 105 = 0$ .

[3]

.....

.....

.....

.....

.....

.....

(c) Use your solutions from part (b) to find the dimensions of the rectangle.  
You must justify any decisions that you make.

[2]

.....

.....

.....

.....

.....

Length of rectangle = ..... cm

Width of rectangle = ..... cm



Examiner  
only

17. Convert  $3.2 \times 10^4$  metres into **miles**.

[3]

.....

.....

.....

.....

.....

.....

.....

.....

.....

.....

.....

.....

.....

.....

.....

.....

$3.2 \times 10^4$  metres is ..... miles



18.  $A, B, C$  and  $D$  are points on the circumference of a circle with centre  $O$ .

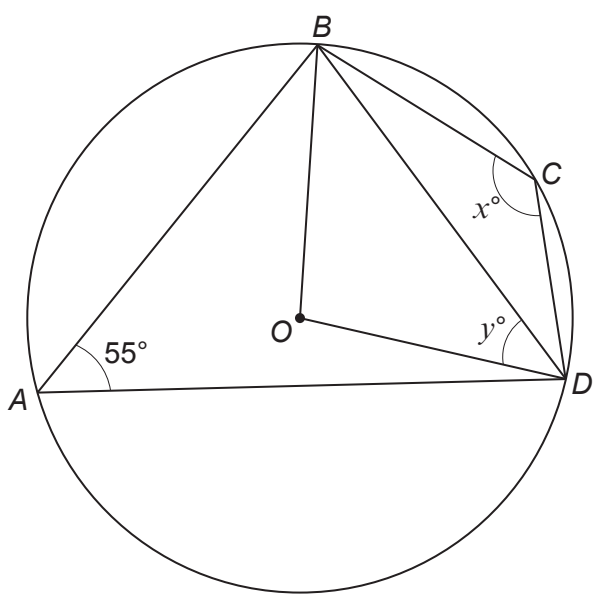

Diagram not drawn to scale

(a) Calculate the value of  $x$ .  
Circle your answer. [1]

- 55°
- 70°
- 110°
- 125°
- 135°

.....

(b) Calculate the value of  $y$ . [3]

.....  
 .....  
 .....  
 .....  
 .....  
 .....  
 .....

**END OF PAPER**



